

# HEAVY DUTY AIR NEEDLE SCALER

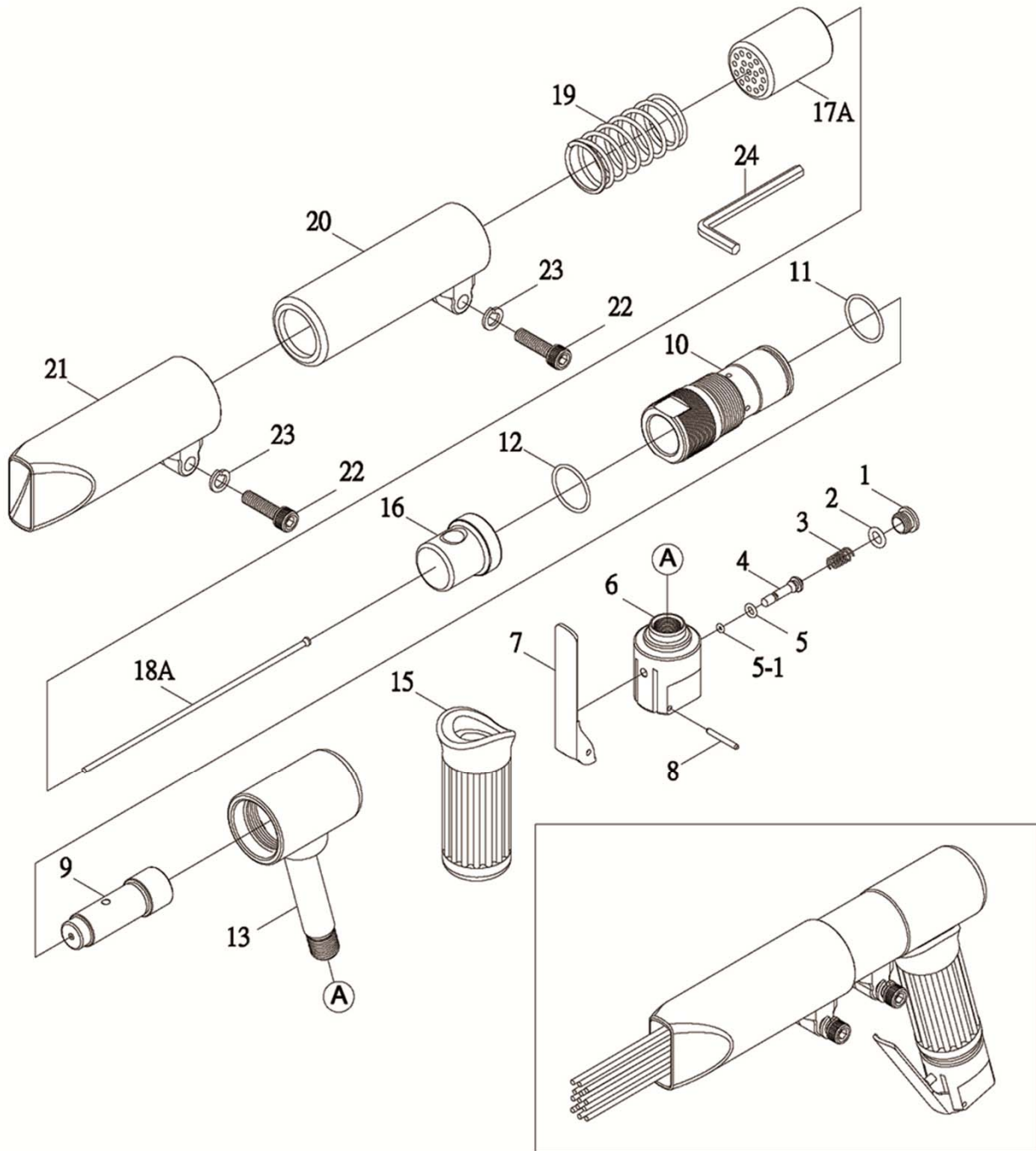

4722-P

INDEX NO.	DESCRIPTION	REQ'D NO.	INDEX NO.	DESCRIPTION	REQ'D NO.
01	Valve Cap	1	13	Handle Housing	1
02	O-Ring	1	15	Rubber Handle Grip	1
03	Valve Spring	1	16	Anvil	1
04	Valve Stem	1	17A	3mm Needle Holder	1
05	O-Ring	1	17B	2mm Needle Holder (Option)	1
05-1	O-Ring	1	18A	3mm Needle(φ3×180L)	19
06	Valve Body	1	18B	2mm Needle(φ2×180L)(Option)	29
07	Throttle Lever	1	19	Spring-Compression	1
08	Spring Pin	1	20	Intermediate Tube	1
09	Piston	1	21	Front Tube	1
10	Cylinder	1	22	Cap Head Screw	2
11	O-Ring	1	23	Washer	2
12	O-Ring	1	24	Hex. Wrench(6mm)	1