

3/8" HEAVY DUTY AIR DRILL

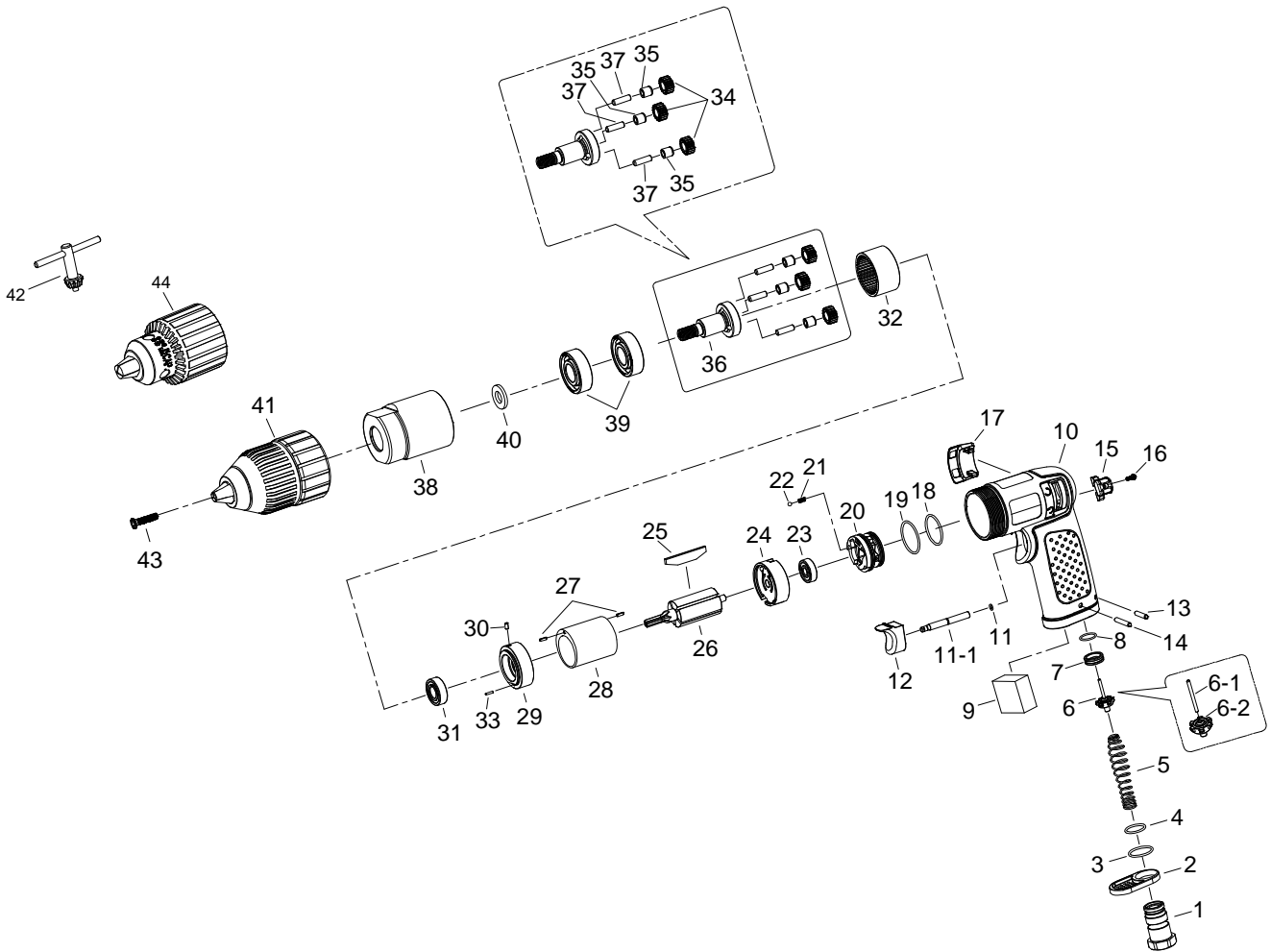

5320

INDEX NO.	DESCRIPTION	REQ'D NO.	INDEX NO.	DESCRIPTION	REQ'D NO.
1	Air Inlet	1	22	Steel Ball	1
2	Exhaust Deflector	1	23	Ball Bearing	1
3	O-Ring	1	24	Rear End Plate	1
4	O-Ring	1	25	Rotor Blade	5
5	Spring	1	26	Rotor	1
★ 6	Throttle Valve Assembly (incl.6-1.6-2)	1	27	Spring Pin	2
● 6-1	Throttle Valve Pin	1	28	Cylinder	1
● 6-2	Throttle Valve	1	29	Front End Plate	1
7	Throttle Valve Seat	1	30	Spring Pin	1
8	O-Ring	1	31	Ball Bearing	1
9	Muffler Element	1	32	Ring Gear	1
10	Motor Housing	1	33	Pin	1
11	O-Ring	1	★ 34	Planet Gear Assembly (incl.35)	3
● 11-1	Trigger Pin	1	● 35	Bushing	3
★ 12	Trigger Assembly (incl.11-1)	1	★ 36	Work Spindle Assembly (incl.37)	1
13	Spring Pin	1	● 37	Pin	3
14	Spring Pin	1	38	Hammer Case	1
15	Reverse Valve Knob	1	39	Ball Bearing	2
16	Screw	1	40	Washer	1
17	Reverse Plate	1	41	Keyless Chuck (Option)	1
18	O-Ring	1	● 42	Chuck Key	1
19	O-Ring	1	43	Screw	1
20	Reverse Valve	1	★ 44	Chuck Assembly (incl.42) (Option)	1
21	Spring	1	TK	Tune-Up Kit { incl.3.4.5.8.9.11.18.19.21.22.25 (5) }	

★ Must be Purchased in Assembly Set

● Recommended not to be purchased alone due to assembly difficulty

20130530R2