

1" SQ. DR. SUPER DUTY IMPACT WRENCH

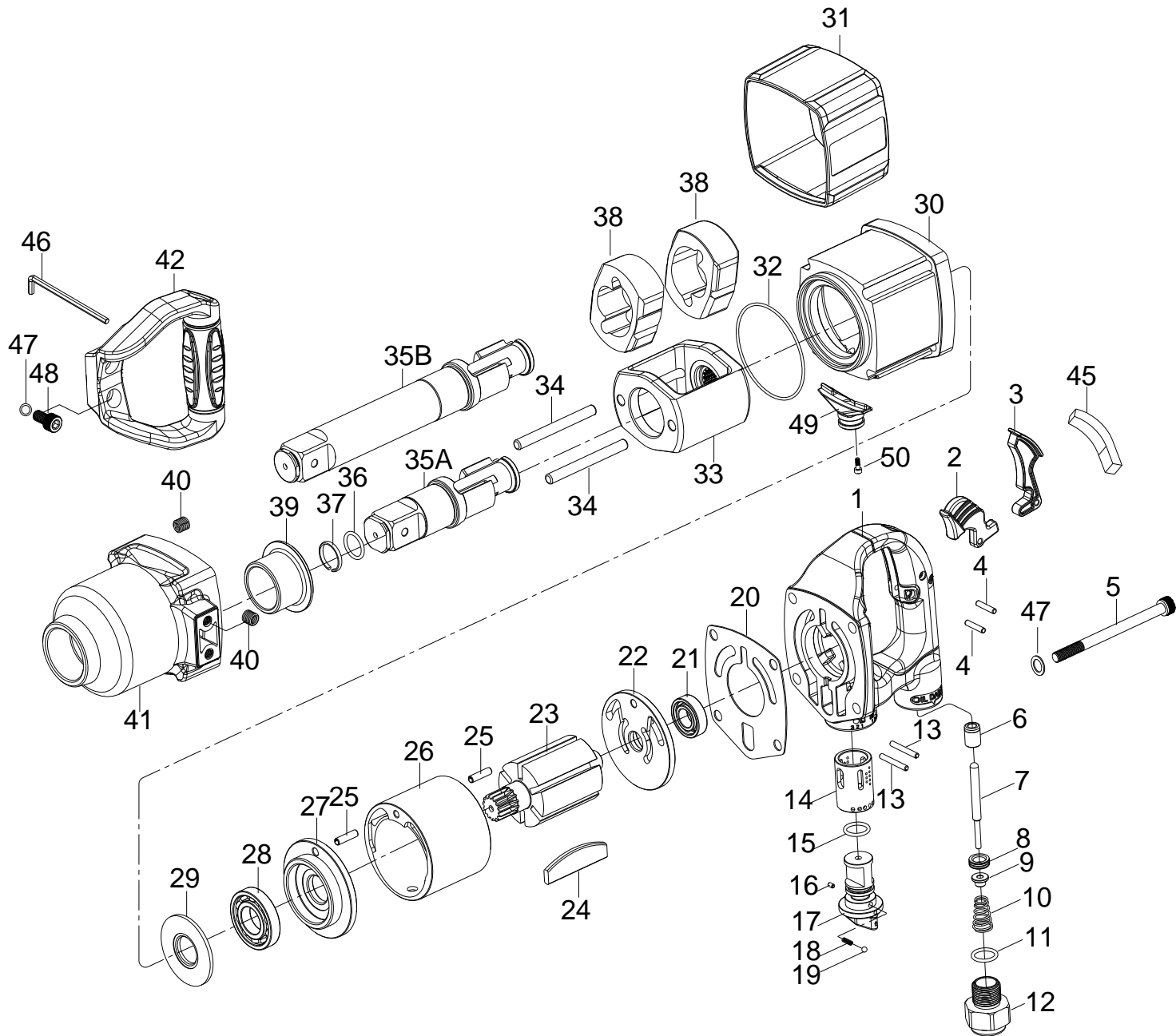

SHP355

INDEX NO.	DESCRIPTION	REQ'D NO.	INDEX NO.	DESCRIPTION	REQ'D NO.
★ 1	Backhead Assembly (incl. 6.14)	1	26	Cylinder	1
2	Inside Trigger (Option)	1	27	End Plate	1
3	Outside Trigger (Option)	1	28	Bearing	1
4	Pin	2	29	Washer	1
5	Screw	4	30	Housing	1
● 6	Bushing	1	31	Rubber Grip	1
7	Throttle Valve Plunger	1	32	O-Ring	1
8	Throttle Valve Seat	1	33	Hammer Frame	1
9	Throttle Valve	1	34	Hammer Pin	2
10	Spring	1	35A	Standard Anvil (for KI-1838A)	1
11	O-Ring	1	35B	6" Extended Anvil (for KI-1838A-6)	1
12	Air Inlet	1	36	O-Ring	1
13	Pin	2	37	Socket Retainer	1
● 14	Reverse Valve Bushing	1	38	Hammer	2
15	O-Ring	1	● 39	Bushing	1
16	Pin	1	● 40	Heli-Coil	6
17	Reverse Valve	1	★ 41	Hammer Case Assembly (incl. 39.40)	1
18	Spring	1	42	Side Spade Handle	1
19	Steel Ball	1	45	Rubber Cap (for Inside Trigger)	1
20	Gasket	1	46	Hex Key Wrench	1
● 21	Bearing	1	47	Washer	6
★ 22	End Plate Assembly (incl. 21)	1	48	Screw	2
23	Rotor	1	49	Exhaust Deflector (Option)	1
24	Rotor Blade	6	50	Screw (for Exhaust Deflecto)	2
25	Pin	2	TK	Tune-Up Kit { incl. 10.11.15.18.19.20.21.24 (6) .28.32.36.37 }	

★ Must be Purchased in Assembly Set

● Recommended not to be purchased alone due to assembly difficulty